

CONSTRUCTION PLAN
16/07/2015

Lot# 6
DP# 1196932
Area: 1392m2

SITE AREA: 1420 sq.m
Floor space ratio: 0.27 :1
Site cover: 364.85 sq.m
Drive/paths: 93.23 sq.m
Open space: 68%

SITE PLAN - SITE ANALYSIS

SCALE 1:200

CLIENT	J. & C. MANTILLA	
JOB	PROPOSED RESIDENCE	
LOCATION	24 PADDOCK CLOSE ELERMORE VALE	
- BUILDER TO CHECK ALL DETAILS AND DIMENSIONS PRIOR TO CONSTRUCTION. - FIGURED DIMENSIONS TAKE PREFERENCE OVER SCALE.		
SHEET	DATE	DWG No.
1 of 11	03/02/2015	6269-CP3

plan prepared by
BUILDTECH
DESIGN & DEVELOPMENT
ACCREDITED BUILDING DESIGNERS ABN 54 539 725 979
Suite 18 - No.1 RELIANCE DRIVE.
TUGGERAH N.S.W. 2259
ph. 4351 8988
fax. 4353 8655
email: buildtech@cccl.net.au

TULLIPAN HOMES PTY LTD

Lic. No. 131446C

PH 02 4353 8644 Suite 18, 1 Reliance Dr
Tuggerah Business Park
Tuggerah NSW 2259
www.tullipanhomes.com.au PO Box 5148
www.splitlevelhomes.com.au CHITTAWAY BAY NSW 2261

Smart Glass SP10 to all windows & doors excluding obscure bathrooms & ensuite windows

FIXING LEGEND

TOWEL RAIL	—
TOILET ROLL	■
TOWEL RING	○

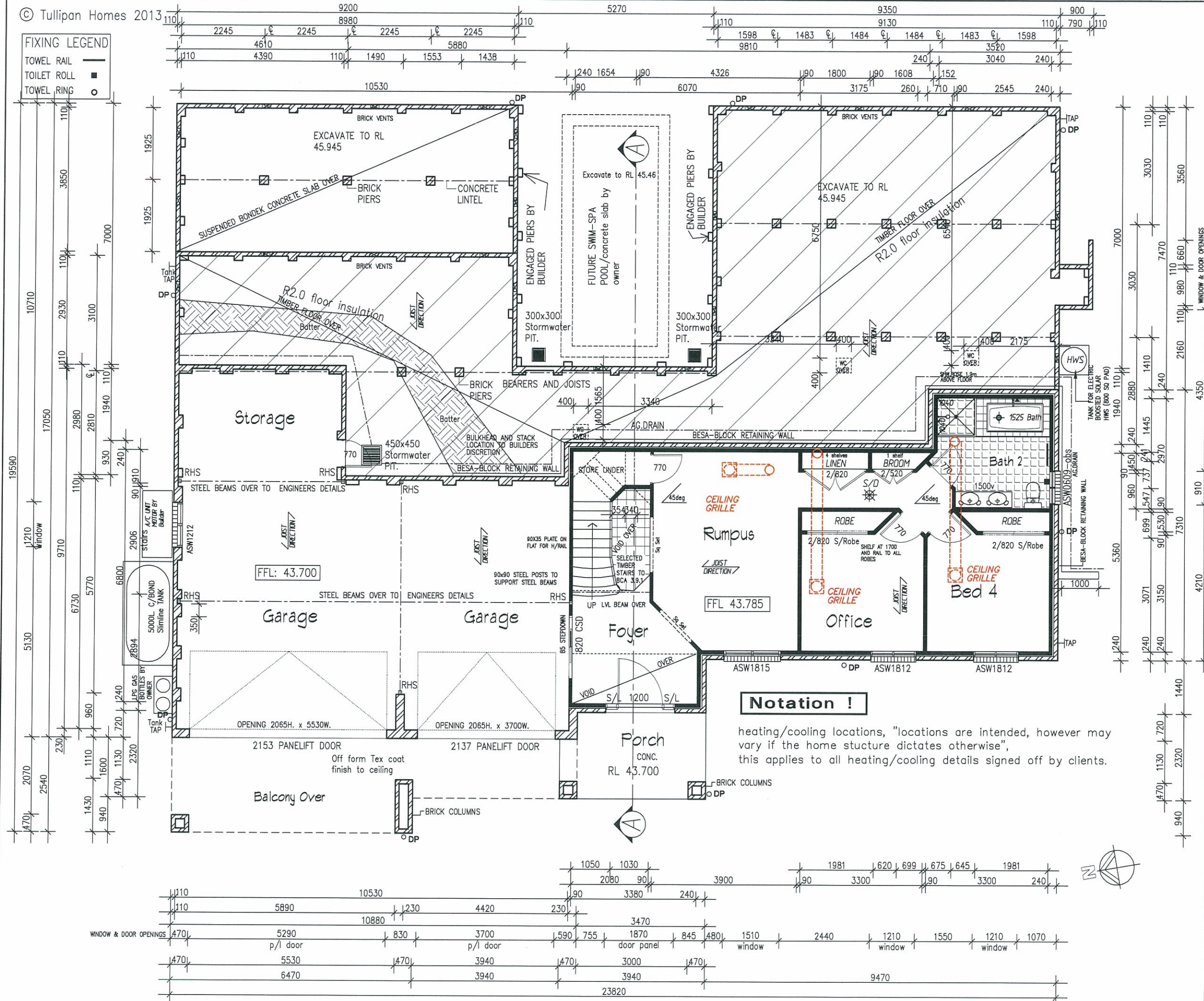

NOTE:
CONSTRUCTION FOR BUSHFIRE
ATTACK LEVEL 29 (BAL-29 & BAL-19).

- MESH GAUDES TO WEEP HOLES & VENTS
- Aluminium Mesh FLYSCREENS
- METAL WEATHER STRIPS TO EXTERNAL DOORS
- SOLID CORE EXTERNAL DOORS - Toughened glass.
- MERBAU Hardwood Door Jambes to hinged External doors.
- BAL29 Metal mesh screen doors to all hinged External Doors - By Owner.
- Provide Ember Seals to the garage door.
- MEDIUM DUTY SARKING - Ridge caps sealed to AS3959.
- Toughend glass must be included to all windows + built to Bal 19/29 regs
- Supply & installation of a mesh &/or mineral wool protection to all Ridges / Hips / Valleys & Fascias in accordance with BAL-29.
- Metal fascia to be fixed at 300mm c/c - provide additional trimmers

AREAS:

Grd Flr Living:	87.63 sqm
Garage:	89.15 sqm
Porch:	8.80 sqm
1st Floor Living:	309.86 sqm
1st Floor Balcony:	31.54 sqm
Alfresco:	36.40 sqm
TOTAL :	563.38 Sqm

60.64 Squares

CONSTRUCTION PLAN
 16/07/2015

Amendments:
 16/07/2015- provide storage area to garage, reposition sub/floor/garage door, provide a/c ducting & diffusers.

Notation !
 heating/cooling locations, "locations are intended, however may vary if the home structure dictates otherwise", this applies to all heating/cooling details signed off by clients.

plan prepared by

BUILDTECH
DESIGN & DEVELOPMENT
 ACCREDITED BUILDING DESIGNERS ABN 54 539 725 979
 Suite 18 - No.1 RELIANCE DRIVE,
 TUGGERAH N.S.W.2259
 ph.4351 8988
 fax.4353 8655
 email:buildtech@cci.net.au

bda BUILDING DESIGNERS AUSTRALIA NSW
 Membership No. 930099

TULLIPAN HOMES PTY LTD
 Lic. No. 131446C
 PH 02 4353 8644 Suite 18, 1 Reliance Dr
 FAX 02 4353 8655 Tuggerah Business Park
 Tuggerah NSW 2259
 www.tullipanhomes.com.au PO Box 5148
 www.splitlevelhomes.com.au CHITTAWAY BAY NSW 2261

CLIENT	J. & C. MANTILLA	
JOB	PROPOSED RESIDENCE	
LOCATION	24 PADDOCK CLOSE ELERMORE VALE	

- BUILDER TO CHECK ALL DETAILS AND DIMENSIONS PRIOR TO CONSTRUCTION.
 - FIGURED DIMENSIONS TAKE PREFERENCE OVER SCALE.

SHEET	DATE	DWG No.
2 of 11	03/02/2015	6269-CP3

GROUND FLOOR PLAN

SCALE 1:100

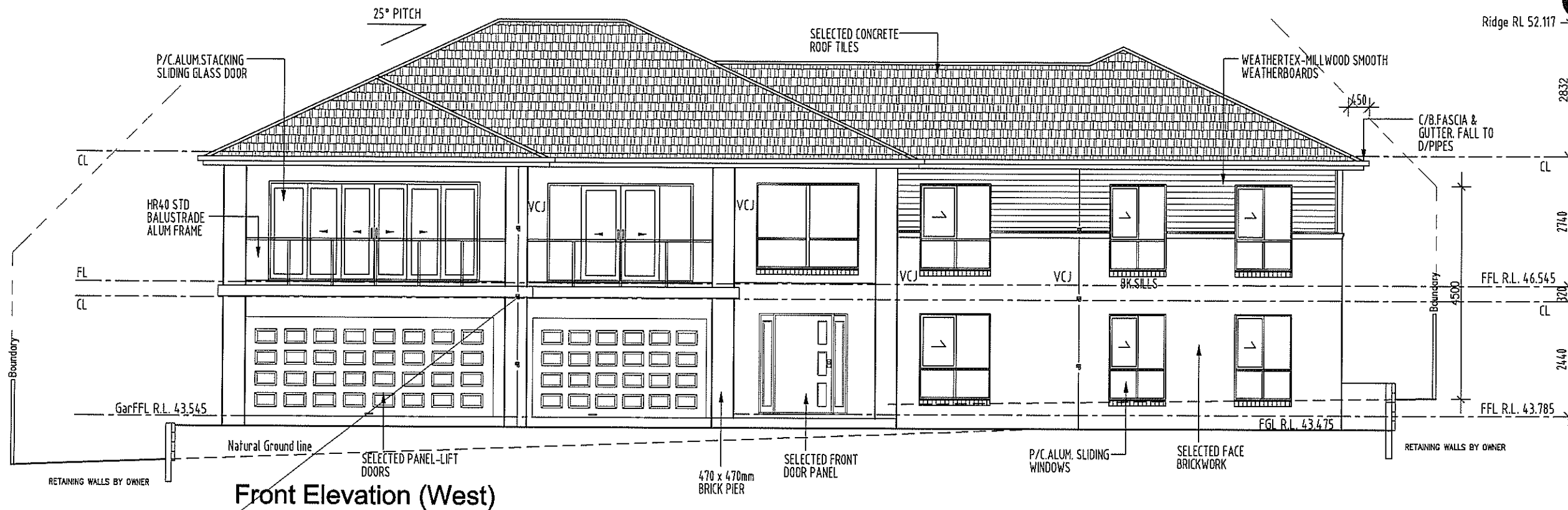

Front Elevation (West)

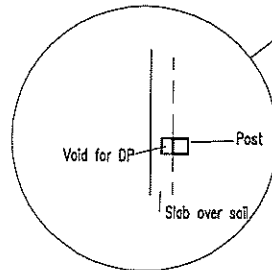

Form Voids in slab overhang

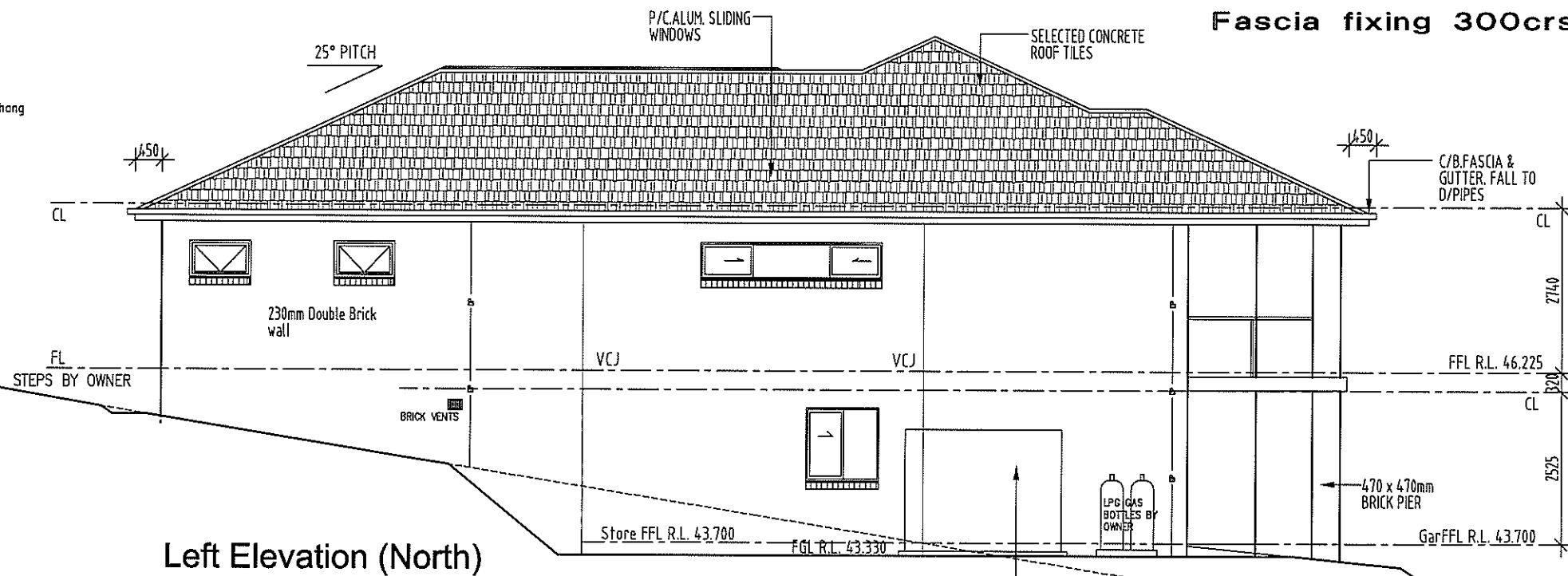

Left Elevation (North)

CONSTRUCTION PLAN

16/07/2015

Amendments:
16/07/2015- provide 230brick walls & windos to alfresco,
& delete concrete balcony over porch.

NOTE:
CONSTRUCTION FOR BUSHFIRE
ATTACK LEVEL 29 (BAL-29 & BAL-19).

- MESH GAURDS TO WEEP HOLES & VENTS
- Aluminium Mesh FLYSCREENS
- METAL WEATHER STRIPS TO EXTERNAL DOORS.
- SOLID CORE EXTERNAL DOORS - Toughened glass.
- MERBAU Hardwood Door Jambs to hinged External doors.
- BAL29 Metal mesh screen doors to all hinged External Doors - By Owner.
- Provide Ember Seals to the garage door.
- MEDIUM DUTY SARKING - Ridge caps sealed to AS3959.
- Toughend glass must be included to all windows + built to Bal 19/29 regs
- Supply & installation of a mesh &/or mineral wool protection to all Ridges / Hips / Valleys & Fascias in accordance with BAL-29.
- Metal fascia to be fixed at 300mm c/c - provide additional Trimmers

ELEVATIONS
SCALE 1:100

CLIENT	J. & C. MANTILLA	
JOB	PROPOSED RESIDENCE	
LOCATION	24 PADDOCK CLOSE ELERMORE VALE	
- BUILDER TO CHECK ALL DETAILS AND DIMENSIONS PRIOR TO CONSTRUCTION. - FIGURED DIMENSIONS TAKE PREFERENCE OVER SCALE.		
SHEET	DATE	DWG No.
4 of 11	03/02/2015	6269-CP3

plan prepared by
BUILDTECH
DESIGN & DEVELOPMENT
ACCREDITED BUILDING DESIGNERS ABN 54 539 725 979
Suite 18 - No.1 RELIANCE DRIVE.
TUGGERAH N.S.W.2259
ph.4351 8988
fax.4353 8655
email:buildtech@cccl.net.au

TULLIPAN HOMES PTY LTD
Lic. No. 131446C
PH 02 4353 8644
FAX 02 4353 8655
www.tullipanhomes.com.au
www.spiritlevelhomes.com.au

Suite 18, 1 Reliance Dr
Tuggerah Business Park
Tuggerah NSW 2259
PO Box 5148
CHITTAWAY BAY NSW 2261



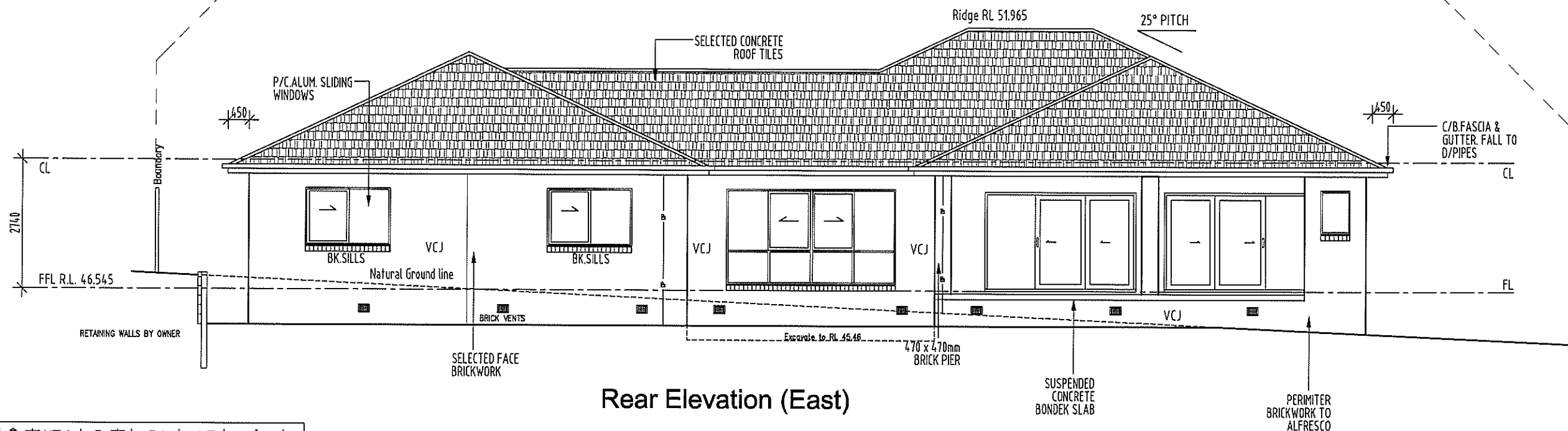

Rear Elevation (East)

CONSTRUCTION PLAN

16/07/2015

Amendments:
16/07/2015- provide 230brick walls & windos to alfresco,
& delete concrete balcony over porch.

Fascia fixing 300crs

NOTE:
CONSTRUCTION FOR BUSHFIRE
ATTACK LEVEL 29 (BAL-29 & BAL-19).

- MESH GAURDS TO WEEP HOLES & VENTS
- Aluminium Mesh FLYSCREENS
- METAL WEATHER STRIPS TO EXTERNAL DOORS.
- SOLID CORE EXTERNAL DOORS - Toughened glass.
- MERBAU Hardwood Door Jambos to hinged External doors.
- BAL29 Metal mesh screen doors to all hinged External Doors - By Owner.
- Provide Ember Seals to the garage door.
- MEDIUM DUTY SARKING - Ridge caps sealed to AS3959.
- Toughend glass must be included to all windows + built to Bal 19/29 regs.
- Supply & installation of a mesh &/or mineral wool protection to all Ridges / Hps / Valleys & Fascias in accordance with BAL-29.
- Metal fascia to be fixed at 300mm c/c - provide additional trimmers

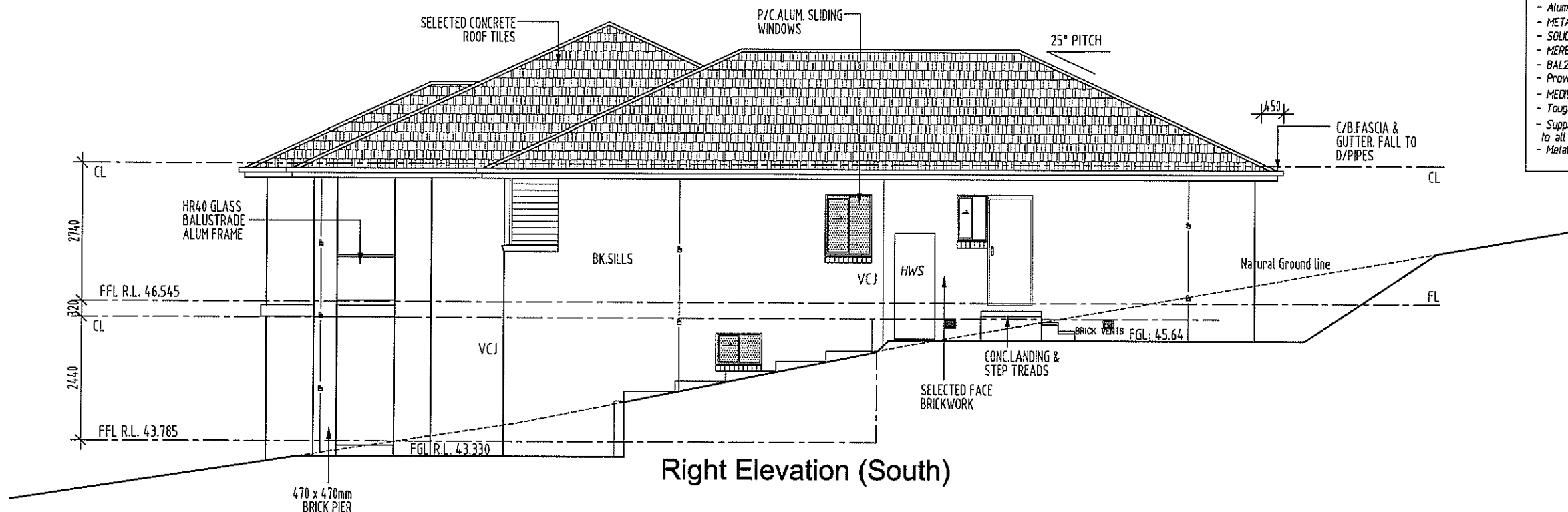

Right Elevation (South)

ELEVATIONS
SCALE 1:100

CLIENT	J. & C. MANTILLA	
JOB	PROPOSED RESIDENCE	
LOCATION	24 PADDOCK CLOSE ELERMORE VALE	
- BUILDER TO CHECK ALL DETAILS AND DIMENSIONS PRIOR TO CONSTRUCTION. - FIGURED DIMENSIONS TAKE PREFERENCE OVER SCALE.		
SHEET	DATE	DWG No.
5 of 11	03/02/2014	6269-CP3

plan prepared by
BUILDTECH
DESIGN & DEVELOPMENT
ACCREDITED BUILDING DESIGNERS ABN 54 539 725 979
Suite 18 - No.1 RELIANCE DRIVE,
TUGGERAH N.S.W.2259
ph.4351 8988
fax.4353 8655
email:buildtech@cccl.net.au

TULLIPAN HOMES PTY LTD
Lic. No. 1314460
PH 02 4353 8644
FAX 02 4353 8655
Suite 18, 1 Reliance Dr
Tuggerah Business Park
Tuggerah NSW 2259
www.tullipanhomes.com.au
www.spitlevelhomes.com.au
PO Box 5148
CHITTAWAY BAY NSW 2261

Fascia fixing 300crs

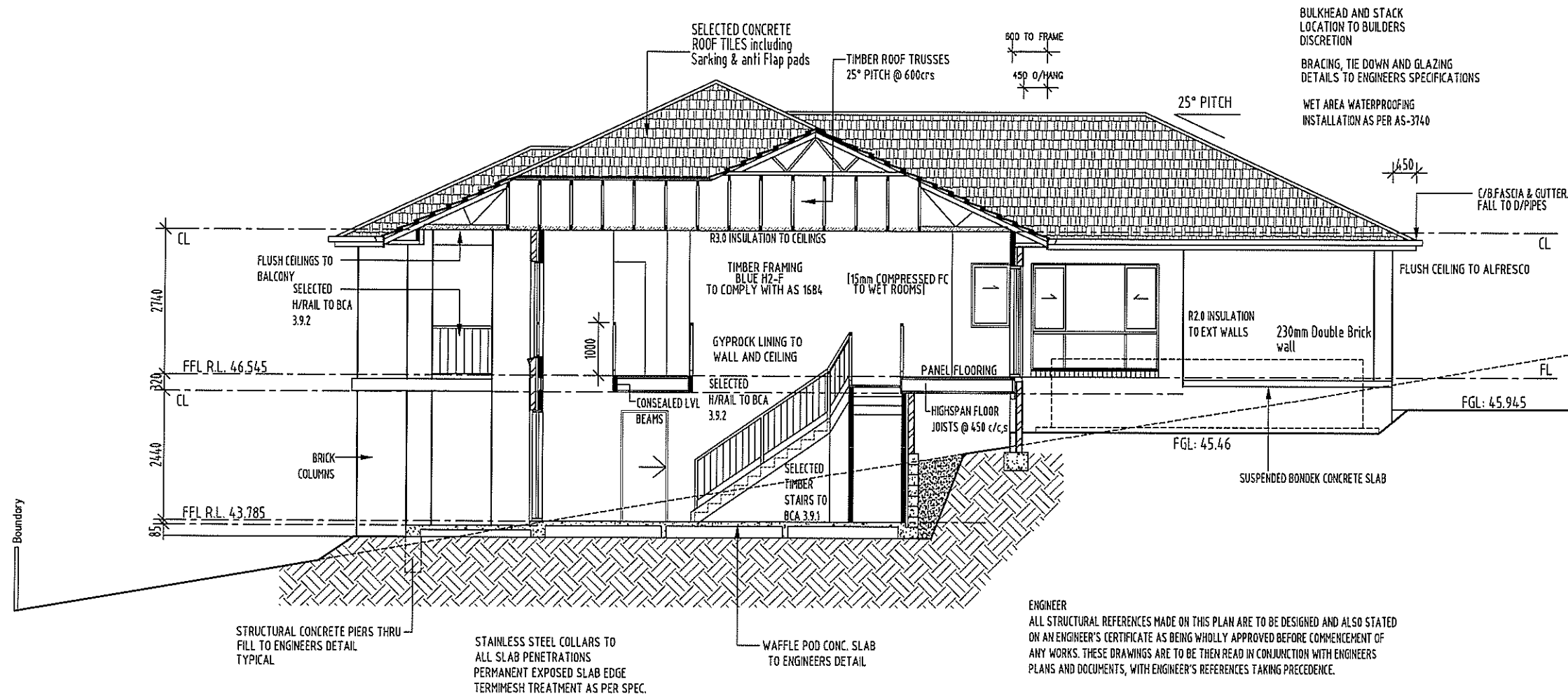

ENGINEER
ALL STRUCTURAL REFERENCES MADE ON THIS PLAN ARE TO BE DESIGNED AND ALSO STATED ON AN ENGINEER'S CERTIFICATE AS BEING WHOLLY APPROVED BEFORE COMMENCEMENT OF ANY WORKS. THESE DRAWINGS ARE TO BE THEN READ IN CONJUNCTION WITH ENGINEERS PLANS AND DOCUMENTS, WITH ENGINEER'S REFERENCES TAKING PRECEDENCE.

SECTION THRU A-A

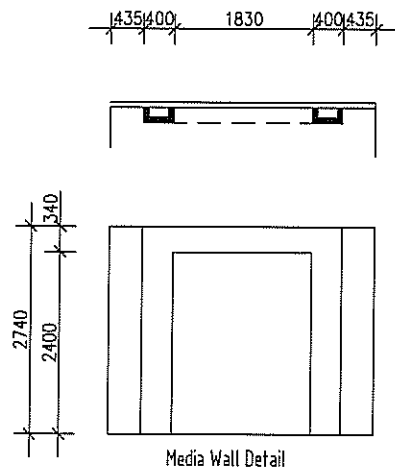

NOTE:
CONSTRUCTION FOR BUSHFIRE ATTACK LEVEL 29 (BAL-29 & BAL-19).

- MESH GAUDES TO WEEP HOLES & VENTS
- Aluminium Mesh FLYSCREENS
- METAL WEATHER STRIPS TO EXTERNAL DOORS.
- SOLID CORE EXTERNAL DOORS - Toughened glass.
- MERBAU Hardwood Door Jambes to hinged External doors.
- BAL29 Metal mesh screen doors to all hinged External Doors - By Owner.
- Provide Ember Seals to the garage door.
- MEDIUM DUTY SARKING - Ridge caps sealed to AS3959.
- Toughend glass must be included to all windows + built to Bal 19/29 regs.
- Supply & installation of a mesh &/or mineral wool protection to all Ridges / Hips / Valleys & Fascias in accordance with BAL-29.
- Metal fascia to be fixed at 300mm c/c - provide additional trimmers

CONSTRUCTION PLAN
16/07/2015

Amendments:
16/07/2015- delete concrete balcony over porch.

CLIENT	J. & C. MANTILLA	plan prepared by	BUILDTECH DESIGN & DEVELOPMENT	TULLIPAN HOMES PTY LTD
JOB	PROPOSED RESIDENCE	ACCREDITED BUILDING DESIGNERS ABN 54 539 725 979		
LOCATION	24 PADDOCK CLOSE ELERMORE VALE	Suite 18 - No.1 RELIANCE DRIVE, TUGGERAH N.S.W.2259	ph.4351 8988	PH 02 4353 8644
		ph.4351 8988	fax.4353 8655	FAX 02 4353 8655
		fax.4353 8655	email:buildtech@ccl.net.au	www.tullipanhomes.com.au
SHEET	DATE	DWG No.	Membership No. 930099	www.splitlevelhomes.com.au
6 of 11	03/02/2015	6269-CP3		PO Box 5148 CHITTAWAY BAY NSW 2261

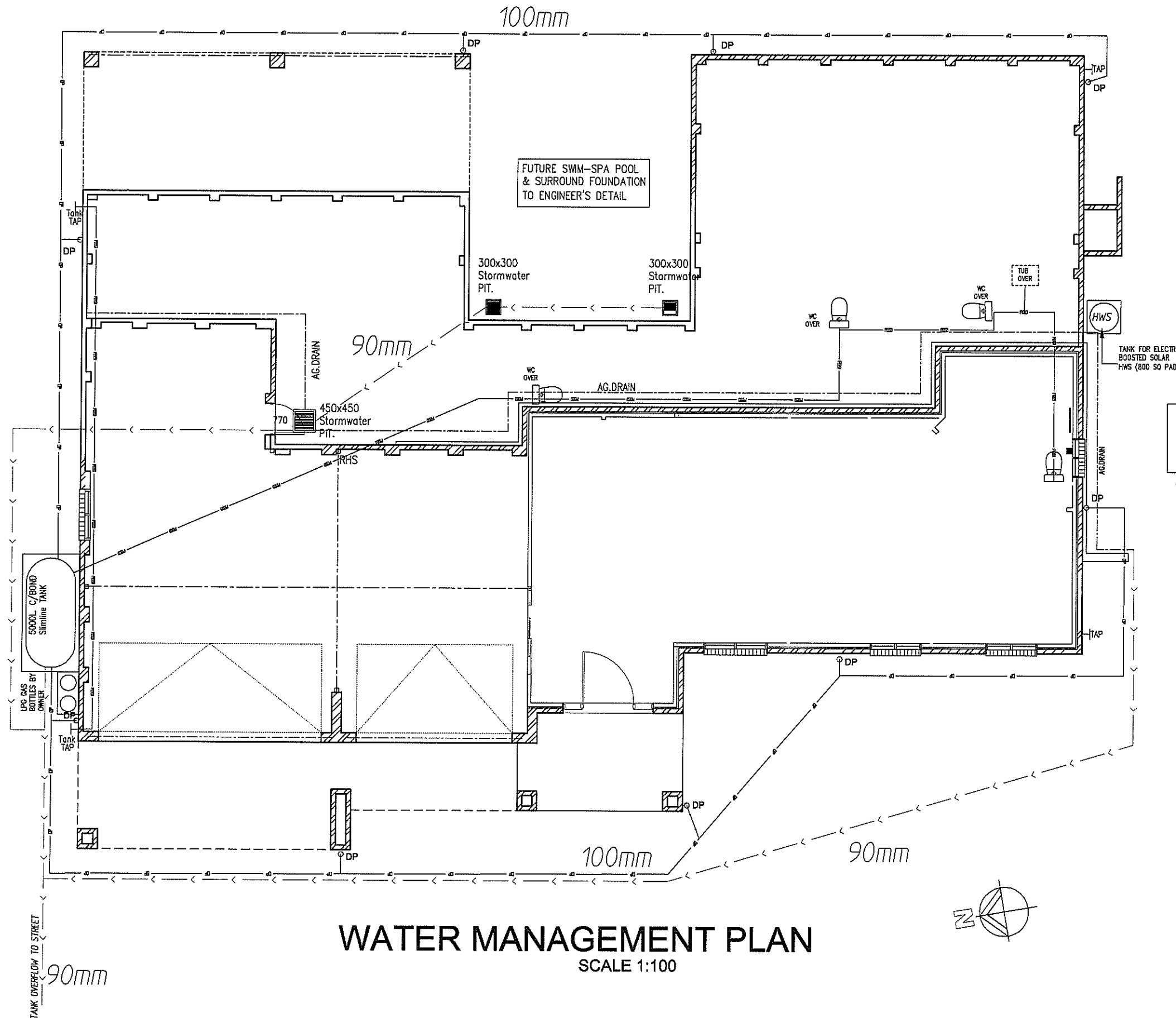
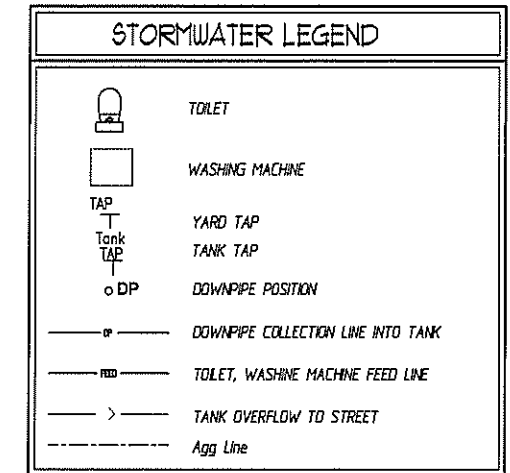

CONSTRUCTION PLAN
16/07/2015

Amendments:
16/07/2015- provide storage area to garage, reposition subfloor/garage door.

WATER MANAGEMENT PLAN

SCALE 1:100

plan prepared by

BUILDTech
DESIGN & DEVELOPMENT

ACCREDITED BUILDING DESIGNERS ABN 54 539 725 979

Suite 18 - No.1 RELIANCE DRIVE,
TUGGERAH N.S.W.2259
ph.4351 8988
fax.4353 8655
email:buildtech@cci.net.au

bda BUILDING DESIGNERS AUSTRALIA NSW
Membership No. 930099

TULLIPAN HOMES PTY LTD

Lic. No. 131446C

PH 02 4353 8644 Suite 18, 1 Reliance Dr
FAX 02 4353 8655 Tuggerah Business Park
Tuggerah NSW 2259
www.tullipanhomes.com.au PO Box 5148
www.spitlevelhomes.com.au CHITTAWAY BAY NSW 2261

CLIENT **J. & C. MANTILLA**

JOB **PROPOSED RESIDENCE**

LOCATION **224 PADDOCK CLOSE
ELERMORE VALE**

- BUILDER TO CHECK ALL DETAILS AND DIMENSIONS PRIOR TO CONSTRUCTION.
- FIGURED DIMENSIONS TAKE PREFERENCE OVER SCALE.

SHEET 7 of 11	DATE 03/02/2015	DWG No. 6269-CP3
------------------	--------------------	---------------------

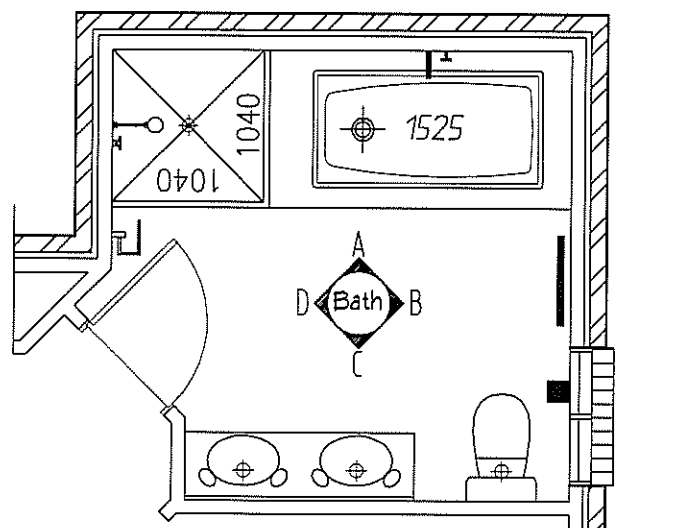

BATH ROOM 2
SCALE 1:50

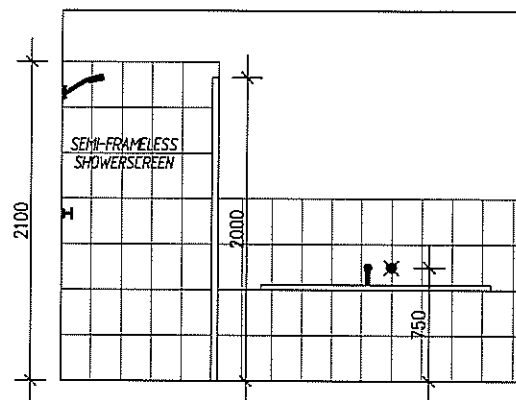

Elevation A

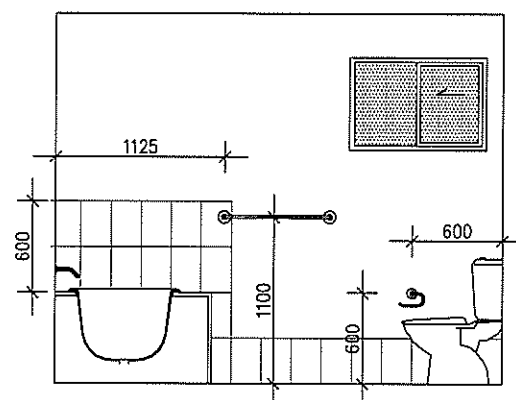

Elevation B

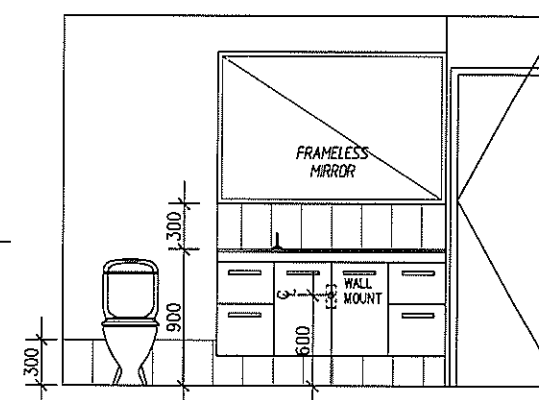

Elevation C

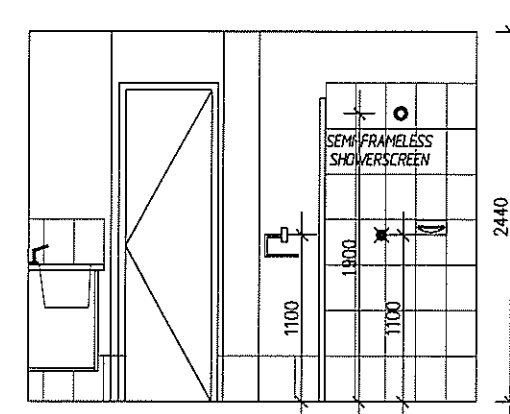

Elevation D

BATH ROOM 2
SCALE 1:50

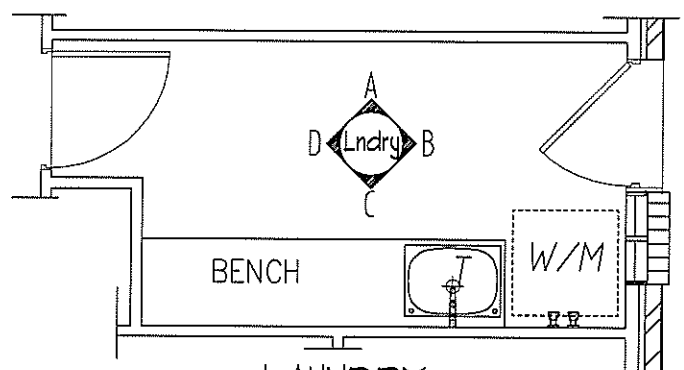

LAUNDRY
SCALE 1:50

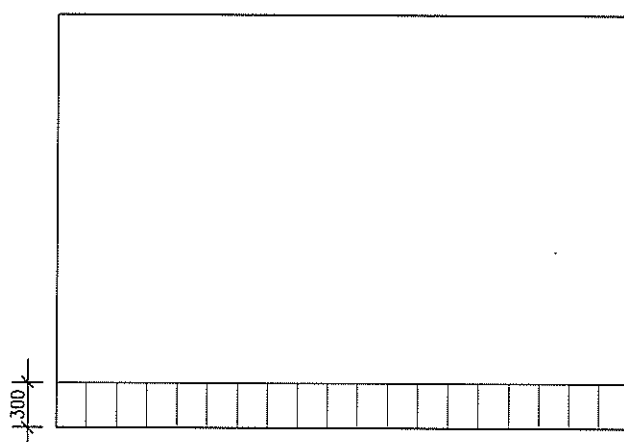

Elevation A

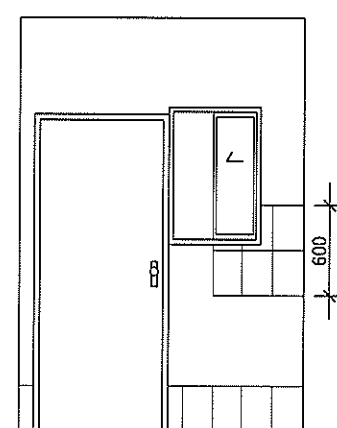

Elevation B

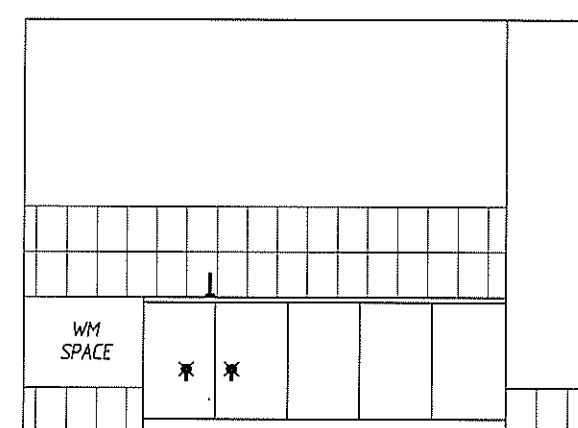

Elevation C

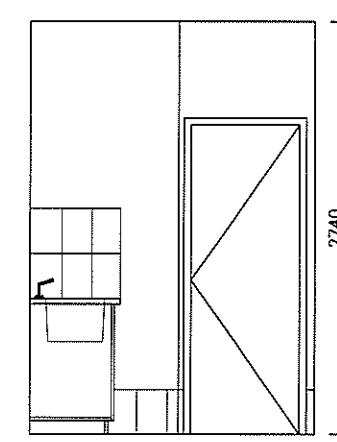

Elevation D

LAUNDRY
SCALE 1:50

CONSTRUCTION PLAN
16/07/2015

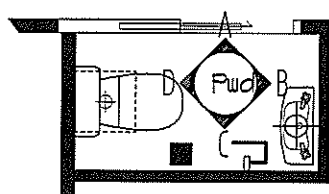

Pwdr Rm
SCALE 1:50

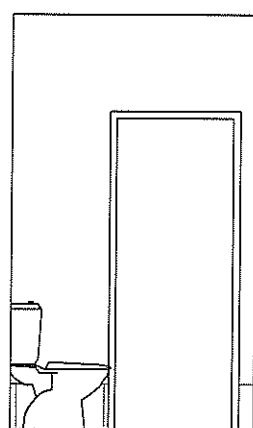

Elevation A

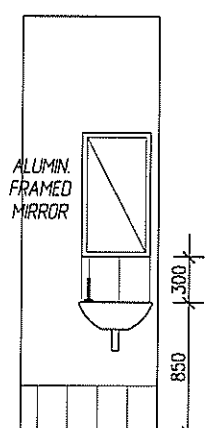

Elevation B

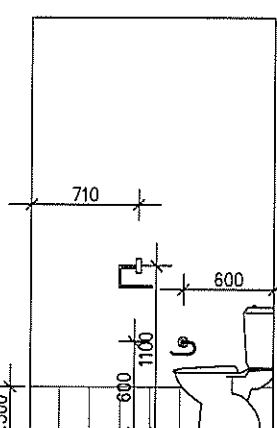

Elevation C

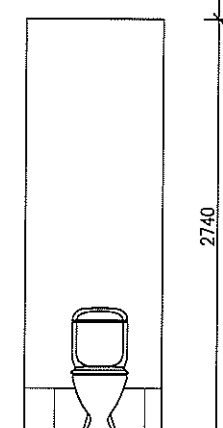

Elevation D

WC.
SCALE 1:50

plan prepared by
BUILDTECH
DESIGN & DEVELOPMENT
 ACCREDITED BUILDING DESIGNERS ABN 54 539 725 979
 Suite 18 - No.1 RELIANCE DRIVE,
 TUGGERAH N.S.W.2259
 ph.4351 8988
 fax.4353 8555
 email:buildtech@cccl.net.au

TULLIPAN HOMES PTY LTD
 Lic. No. 131448C
 PH 02 4353 8644
 FAX 02 4353 8655
 www.tullipanhomes.com.au
 www.spitlevelhomes.com.au
 Suite 18, 1 Reliance Dr
 Tuggerah Business Park
 Tuggerah NSW 2259
 PO Box 5148
 CHITTAWAY BAY NSW 2261

CLIENT	J. & C. MANTILLA	
JOB	PROPOSED RESIDENCE	
LOCATION	Lot 6 PADDOCK CLOSE ELERMORE VALE	
- BUILDER TO CHECK ALL DETAILS AND DIMENSIONS PRIOR TO CONSTRUCTION. - FIGURED DIMENSIONS TAKE PREFERENCE OVER SCALE.		
SHEET	DATE	DWG No.
A - A	29-07-2013	6269-CP3



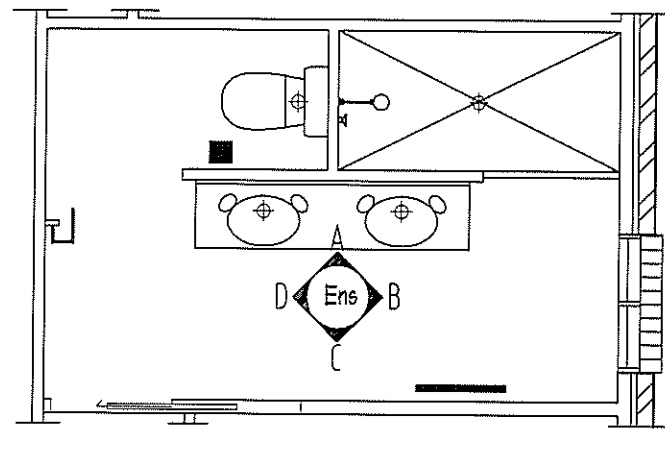

ENSUITE
SCALE 1:50

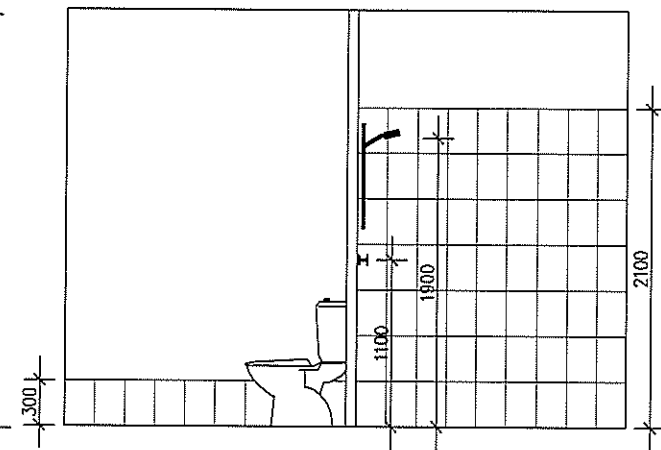

Elevation A

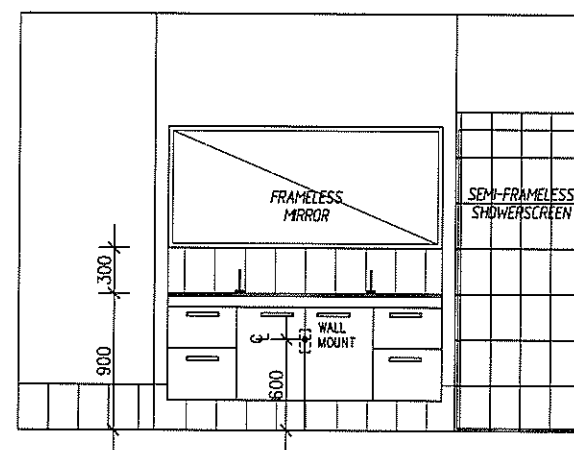

Elevation A-2

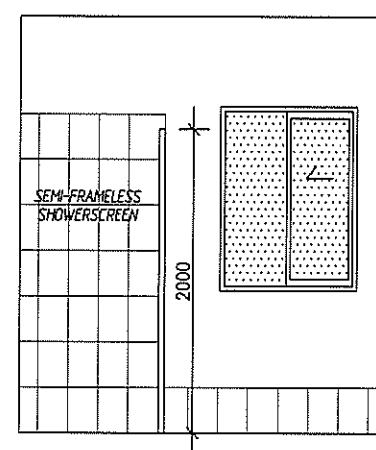

ENSUITE
SCALE 1:50

Elevation B

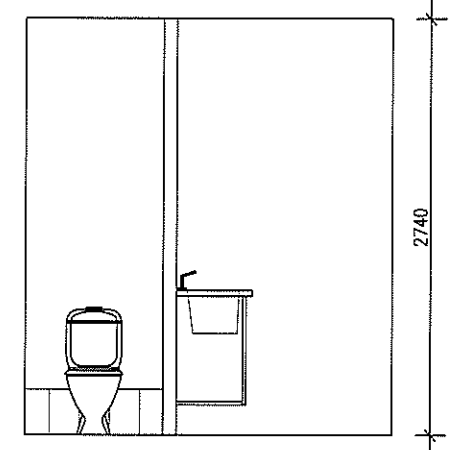

Elevation B-2

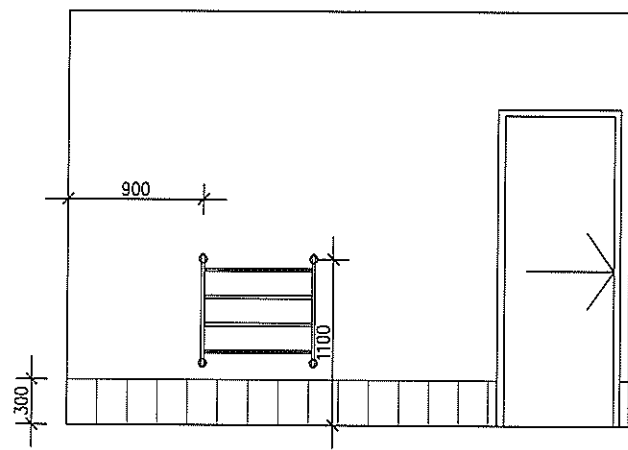

Elevation C

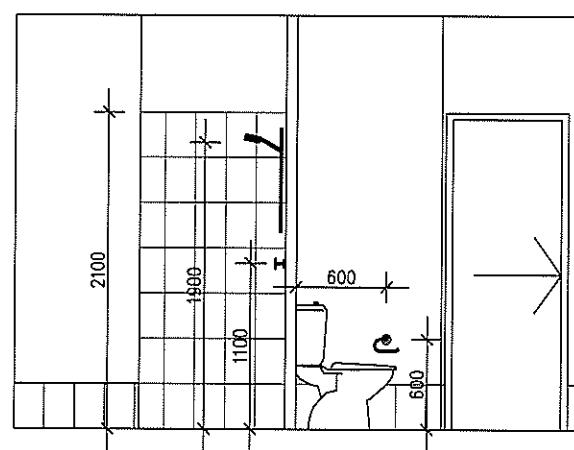

Elevation C-2

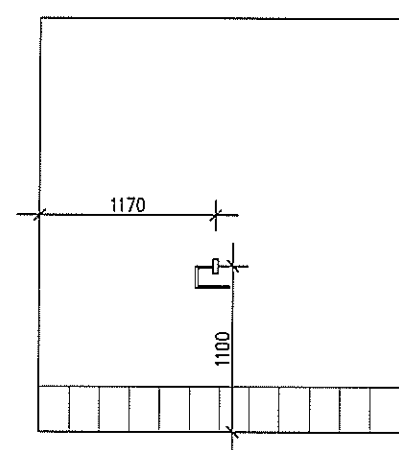

ENSUITE
SCALE 1:50

Elevation D

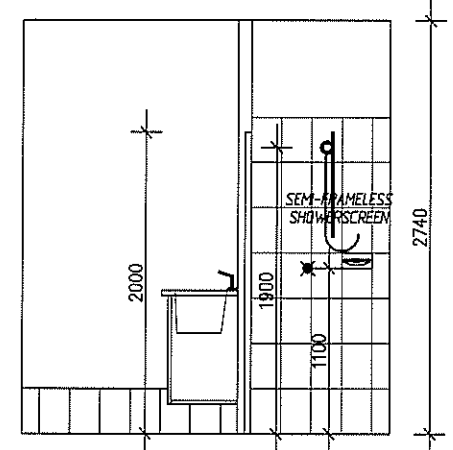

Elevation D-2

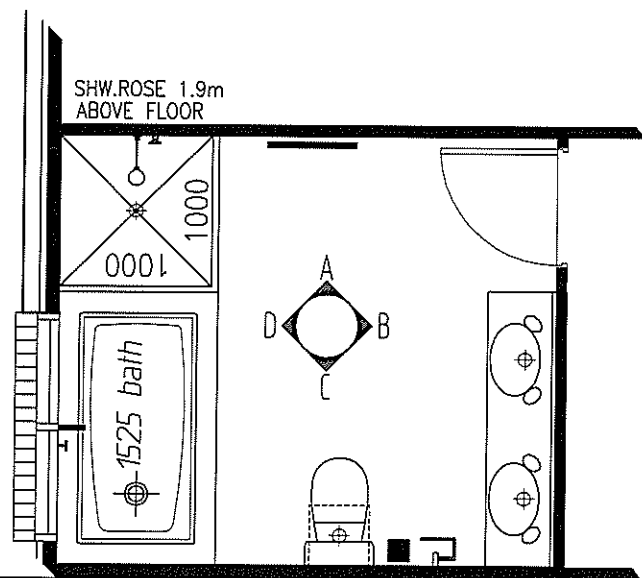

BATH ROOM 1
SCALE 1:50

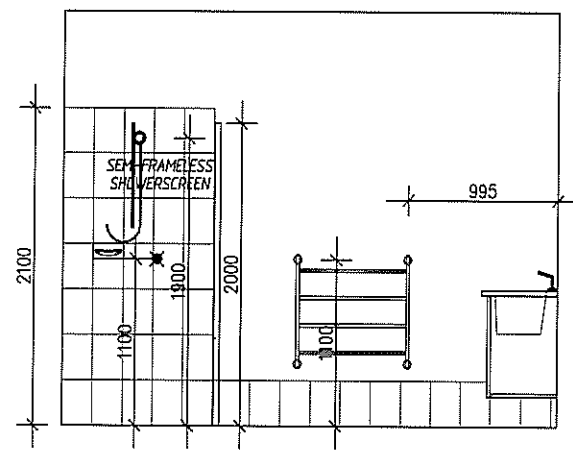

Elevation A

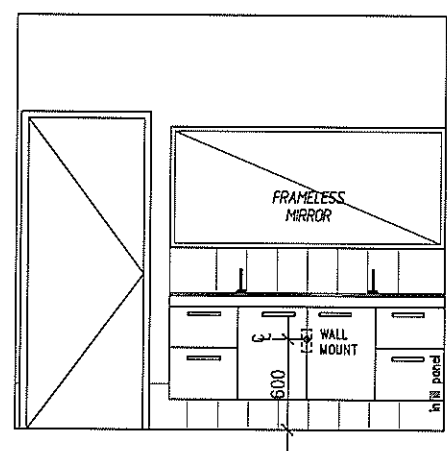

Elevation B

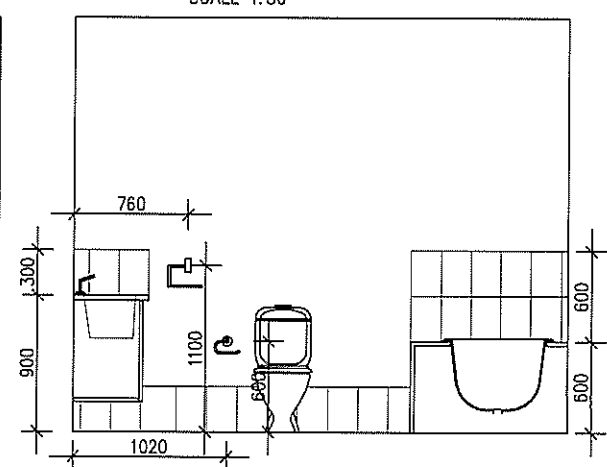

BATH ROOM 1
SCALE 1:50

Elevation C

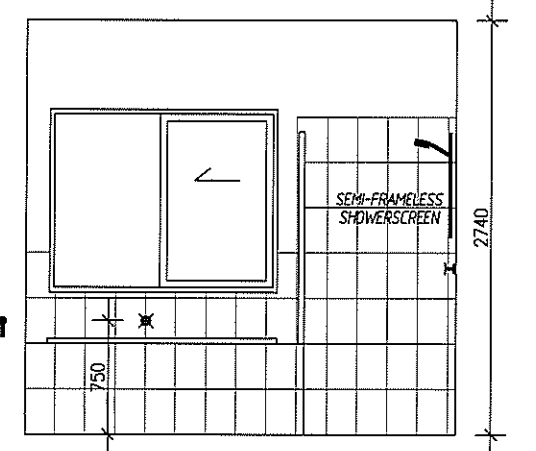

Elevation D

CONSTRUCTION PLAN
16/07/2015

CLIENT	J. & C. MANTILLA	
JOB	PROPOSED RESIDENCE	
LOCATION	Lot 6 PADDOCK CLOSE ELERMORE VALE	
- BUILDER TO CHECK ALL DETAILS AND DIMENSIONS PRIOR TO CONSTRUCTION. - FIGURED DIMENSIONS TAKE PREFERENCE OVER SCALE.		
SHEET	DATE	DWG No.
A - B	29-07-2013	6269-cp3

plan prepared by
BUILDTECH
DESIGN & DEVELOPMENT
ACCREDITED BUILDING DESIGNERS ABN 54 539 725 979
Suite 18 - No.1 RELIANCE DRIVE,
TUGGERAH N.S.W.2259
ph.4351 8988
fax.4353 8655
email:buildtech@cci.net.au

TULLIPAN HOMES PTY LTD
Lic. No. 131446C
PH 02 4353 8644
FAX 02 4353 8655
Suite 18, 1 Reliance Dr
Tuggerah Business Park
Tuggerah NSW 2259
www.tullipanhomes.com.au
www.splitlevelhomes.com.au
PO Box 5148
CHITTAWAY BAY NSW 2261

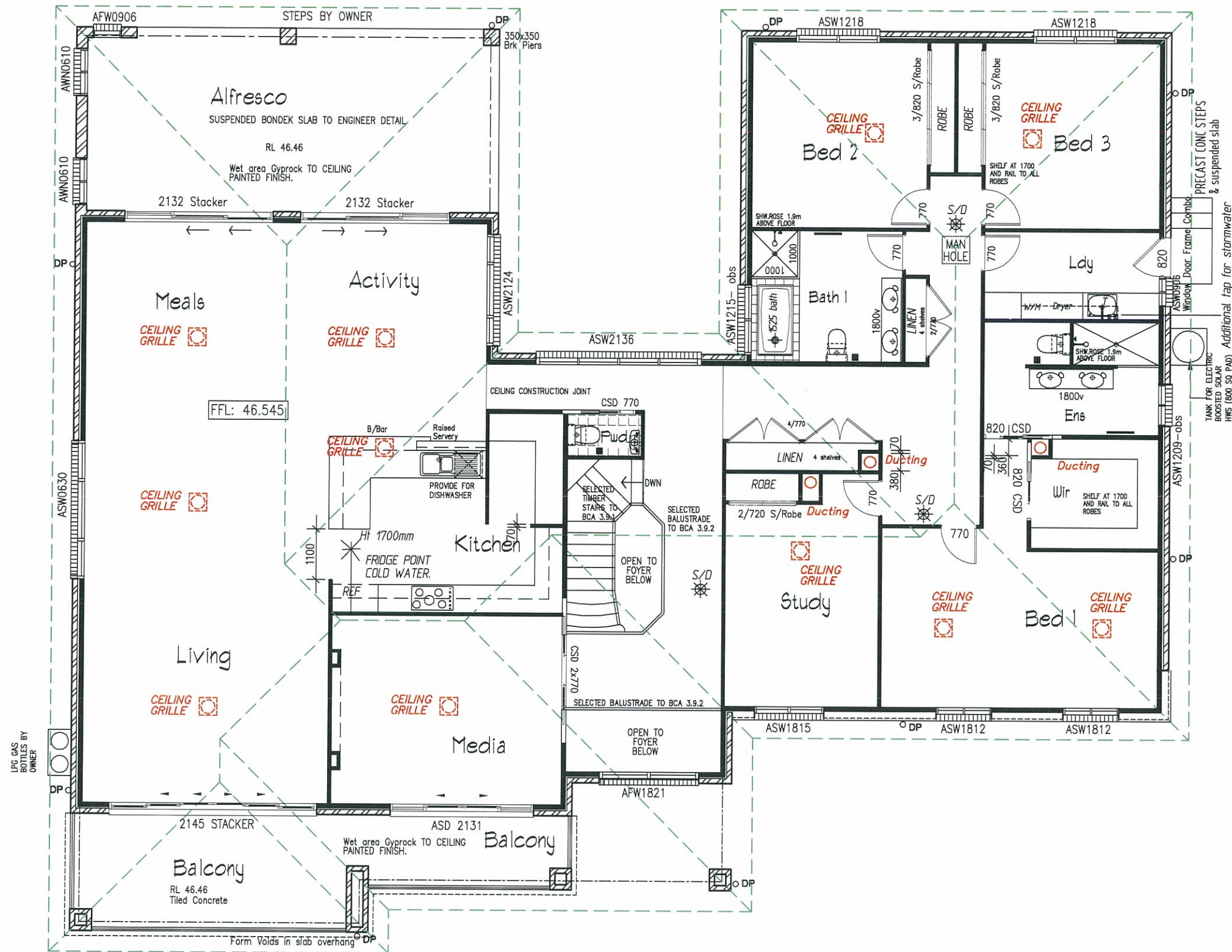

GAS PLAN
SCALE 1:100

CLIENT	J. & C. MANTILLA	
JOB	PROPOSED RESIDENCE	
LOCATION	Lot 6 PADDOCK CLOSE ELERMORE VALE	
- BUILDER TO CHECK ALL DETAILS AND DIMENSIONS PRIOR TO CONSTRUCTION. - FIGURED DIMENSIONS TAKE PREFERENCE OVER SCALE.		
SHEET	DATE	DWG No.
11 of 11	29-07-2013	6269-cp3

plan prepared by
BUILDTECH
DESIGN & DEVELOPMENT
 ACCREDITED BUILDING DESIGNERS ABN 54 539 725 979
 Suite 18 - No.1 RELIANCE DRIVE,
 TUGGERAH N.S.W.2259
 ph.4351 8988
 fax.4353 8655
 email:buildtech@cci.net.au

TULLIPAN HOMES PTY LTD
 Lic. No. 131446C
 PH 02 4353 8644
 FAX 02 4353 8655
 Suite 18, 1 Reliance Dr
 Tuggerah Business Park
 Tuggerah NSW 2259
 www.tullipanhomes.com.au
 www.splitlevelhomes.com.au
 PO Box 5148
 CHITTAWAY BAY NSW 2261